

SF 1500

FREQUENCY CONVERTER

ENGLISH

INSTALLATION & USER INSTRUCTIONS

CONTENTS

1. SAFETY

1.1 Safety instructions.....	3
1.2 Safety measures.....	3
1.3 Permitted use.....	3

2. INSTALLATION

2.1 Overview.....	4
2.2 Spindle/motor connecting.....	4
2.3 Power connecting.....	4
2.4 Wiring diagram.....	5

3. OPERATION

3.1 Overview.....	6
3.2 Putting to operation.....	6
3.3 Putting out of operation.....	6

4. TROUBLESHOOTING

4.1 LED messages.....	7
4.2 Error messages.....	7
4.3 Service.....	7

5. TECHNICAL DATA

5.1 Overview.....	8
5.2 Specifications.....	8
5.3 Certifications.....	8

GENERAL INFORMATION

Thank you for purchasing this SPV Spintec product. Please read this manual so you know how to operate your model properly. After reading the instructions, put them in a safe place for further use.

If for any reason you would need to contact us, please visit our web site at www.spvspintec.se for full contact information.

THE MANUAL'S EDITION

This manual is the edition: P02 (20101213)
Document. no: SF1500-M-EN

The manual always comes in the latest edition along with the equipment. On our web site, you can always download the latest version. We reserve the rights to make changes in the construction, both mechanical and electrical.

SPV SPINTEC AB
BOX 303
SE-631 04 ESKILSTUNA
SWEDEN

TEL: +46 - 16 - 15 30 30

E-MAIL: info@spvspintec.se

WEB SITE: www.spvspintec.se

1.1 SAFETY INSTRUCTIONS

The following symbols appear in this manual. Make sure that you recognize and understand what they mean.



WARNING!

Improper use may result in damage or malfunction of the equipment.



DANGER due to electrical voltage!

Improper handling can cause severe personal injury.



DANGER due to rotating parts!

Improper operation can cause severe personal injury.

1.2 SAFETY MEASURES

Always read the installation instructions first and consider the safety notes.

Always beware of dangers, when working with electrical systems:

- Electric voltage
- Within 10 minutes after disconnecting the device it still can contain electricity. Make sure that the voltage is gone!
- Moving parts
- Hot surfaces

Your knowledge:

- To prevent personal injury and device damages, only people with sufficient knowledge of electrical engineering are allowed to use this device
- The qualified person has to be familiar with the installation instructions

Knowledge about the national rules:

- Consider following, during installation
- Connection conditions and technical data must be followed
- The rules of electrical installation must be followed, for example cable area, protection conductors and ground connection
- Do not touch electric parts or connections. (Electrical discharge can damage components)

1.3 PERMITTED USE

IMPORTANT! SAVE THIS MANUAL FOR FUTURE REFERENCE.

SPV Spintec's motors and frequency-converters are devices which are intended for use in electronic equipment or machines.

By putting the device to operation (with current standards) it must be taken into account that the entire machine shall comply with the machinery directive (89/392/EWG) and EN 60204 (machine safety). If the equipment is used in special facilities, for example explosion hazardous environments, specific standards (such as EN 50014 "General provisions" and EN 50018 "Gas-proof enclosures") must be followed. Service or repair shall only be done by authorized service personnel. Unauthorized disassembling can cause property damage and personal injury which SPV Spintec not are responsible for.

1. Consider the work area environment.

Keep the work area well lit. Do not use the device where there is risk to cause fire or explosion, such as in the presence of flammable liquids or gases.

2. Keep unauthorized people away.

Do not let people, especially children, who are not involved in the work, touch the equipment and keep them away from the work area.

3. Use safety equipment.

Always wear safety glasses. Use a face shield or dust protection if the process produce dust or flying particles. If these particles are very hot, also wear a heat-resistant apron. Always wear ear protection.

4. Connect dust purging equipment.

If there are devices for connecting apparatus for cleansing and collecting of pond, ensure that they are connected and used properly.

8. Contact SPV Spintec for service.

This equipment complies with the relevant safety-requirements. Repair and service should be performed only by trained personnel using genuine parts. Otherwise, this may result in danger to the operator. Always contact SPV Spintec at these times.

2.1 OVERVIEW

SPINDLE CONNECTION
(Output max 230V 1600Hz)

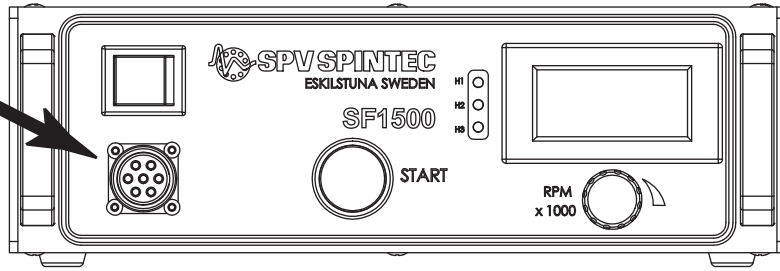

FUSE HOLDER
(Fuse = 5 x 20 mm 10A (T))

MAIN POWER CONNECTION
(Input 230 V AC 50/60 Hz)

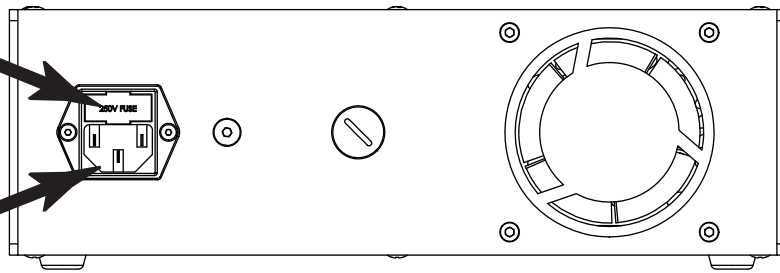

2.2 SPINDLE / MOTOR CONNECTING

IMPORTANT! Always use a shielded cable for the spindle connection.

- Connect the cable's female connector to the connector on the spindle / motor.
- Then connect the cable's male connector to the spindle connector on the frequency converter.
- Make sure that the cable's screw connectors are stuck.



DANGER !

Due to electrical voltage! Improper use may cause injury or death. Only people with sufficient knowledge of electrical engineering are allowed to do the connecting.

2.3 POWER CONNECTING

IMPORTANT! Always use the cable supplied in the delivery.

- Make sure that the power switch on the front panel is in position "OFF"
- Connect the power cord to the socket connector on the frequency converter.
- Then connect the plug to a ground protected wall outlet (230 V)



CAUTION !

Always follow the connecting order described in this manual. Otherwise it can cause damage to the equipment.

2.4 WIRING DIAGRAM

Programmable in/outputs

SPV Spintec ROT6 standard settings for digital outputs (X2)

OSD02 Active, (Relay 19-20) unit is OK, waiting for start signal.

OSD01 Active, (+24V 16 - GND 17) when the motor is stopped.

OSD00 Active, (+24V 15 - GND 17) when the motor is running at preset speed.

SPV Spintec standard settings for analog inputs (X2)

ISA00 RPM-control, 0-10V from potentiometer or external voltage source.

STR Start, right-rotation.

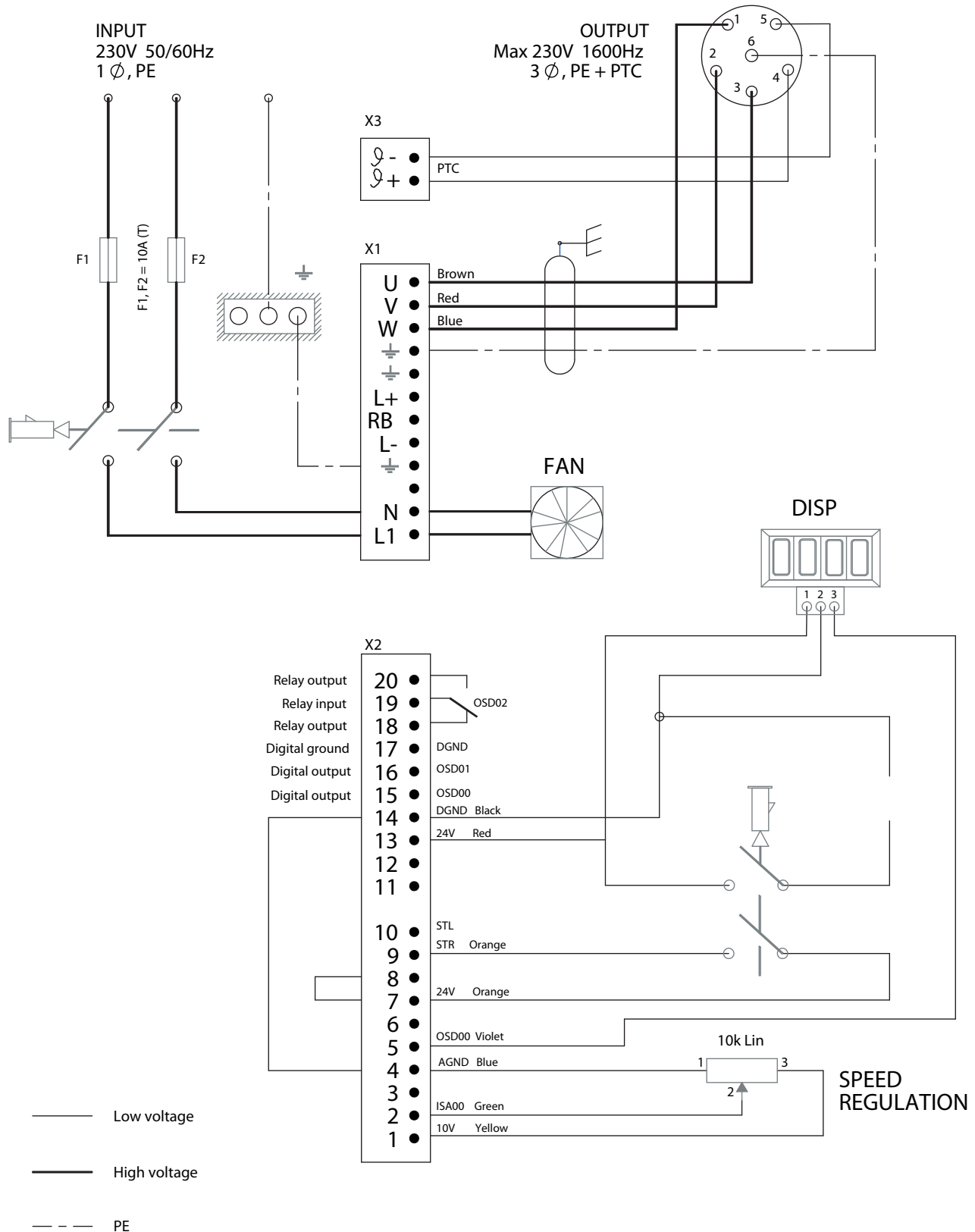

3.1 OVERVIEW



3.2 PUTTING TO OPERATION

1. Make sure the equipment is correctly connected. Read chapter 2 for installation.
2. Start up the equipment by switching the main switch to "ON".
3. Make sure the knob for RPM regulation is set to minimum (counter clockwise to stop)
4. Start the spindle by pushing the spindle start/stop button.
5. Turn the knob for RPM regulation clockwise to achieve the desired speed which is controlled by reading the display.



DANGER due to rotating parts!

Improper operation can cause severe personal injury.

3.3 PUTTING OUT OF OPERATION

1. Turn the spindle off by pushing the spindle start/stop button.
2. Turn the knob for RPM regulation counter clockwise to stop.
3. Switch of the main switch to turn the power off.
4. If the equipment is to be switched off for a long time, unplug it from the wall socket.

4.1 LED MESSAGES

On the front panel of the converter there are three LED's. These are located directly to the left of the RPM display and has the colors, RED (H1), YELLOW (H2) and GREEN (H3) for status indication.

STATUS LED'S



Device mode	Ha (Red)	Ha (Yellow)	H3 (Green)
Connected	○	○	●
Ready	○	●	●
I drift	○	☀	●
Warning	●	●/☀	●
Error	☀ (CODE)	○	●

○ = LED off

● = LED lit

☀ = LED flashing

4.2 ERROR MESSAGES

If an error occurs during operation, the red LED (H1) on the front panel of the converter flashes. The flashing code indicates an error message according to the table below.

Flashing code. Red LED (H1)	Error message	Cause / Action
1 X	Converter CPU error	Shut down the device, disconnect the power cord. Contact SPV Spintec if the error recurs.
2 X	Low voltage shutdown	Check the input voltage. This signal occurs shortly when turning of the power normally.
3 X	High power shutdown	Short circuit, ground error. Check the power cables, neutral wire and ground wiring.
4 X	High voltage shutdown	Input voltage overload: Check the input voltage and restart the device.
5 X	Spindle protection shutdown	Spindle overload: Extend the machine cycle if possible. Insufficient spindle?
6 X	Converter protection shutdown	Converter overload: Check the spindle. A more powerful converter might be needed.
7 X	Spindle temperature too high	Is the spindle PTC correctly connected? Spindle overload? Let the spindle cool down.
8 X	Converter temperature too high	Surrounding temperature too high: Increase cooling around the device. Too high load during operation: Check the spindle. In some cases a break resistor can be connected.



CAUTION !

Never try to repair the frequency converter on your own.
Always contact SPV Spintec for support.

4.3 SERVICE

SPV Spintec repairs and perform service on all of our spindles and converters. Contact us either by e-mail to: info@spvspintec.se or by telephone to +46 - 16 - 15 30 30.

5.1 OVERVIEW

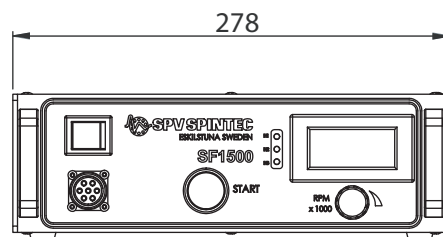
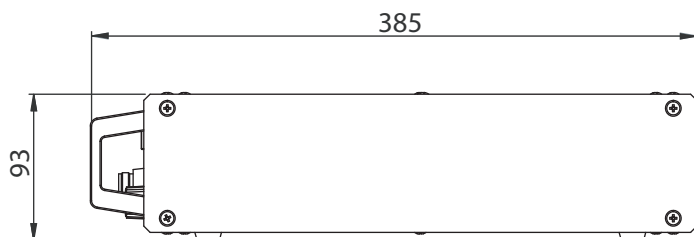

5.2 SPECIFICATIONS

INPUT	
Input voltage	230 V AC
Frequency	50 / 60 Hz (±10%)
Fuse	10A (T)
Effect loss	105 W
OUTPUT, SPINDLE	
Recommended rate effect with 4-pole, standard spindle.	1,5 kW
Device effect	3,0 kVA
Continuous power	7,1 A
PHYSICAL DATA	
Dimensions (mm)	280 x 385 x 95
Weight	4.5 kg
Enclosure sealing	IP20
Working temperature	-10 to +45°C

The SF 1500 frequency converter is compatible with the following SPV Spintec spindles.

- VM 10
- VM 17
- S11-72
- S16-60
- S18-60
- S19-60
- S20-60
- S21-60
- S21-90
- S24-75
- S34-45
- S27-30
- S27-38
- S27-40
- S27-54

5.3 CERTIFICATIONS



All SPV Spintec frequency converters are CE-approved and EMC-tested according to EMC-directives 89/336/EEC with tests EN 50 081-2 (1993) and EN 50 082-2 (1995).



SPV SPINTEC AB
BOX 303
SE-631 04 ESKILSTUNA
SWEDEN

TEL: +46 - 16 - 15 30 30

E-MAIL: info@spvspintec.se

WEB SITE: www.spvspintec.se